

AUTOCLEAR 5333

Portable, Compact Parcel X-ray For Explosives, Weapons & Narcotics



***Lower profile, bottom-up design makes items and fine lines much sharper and larger on-screen.**

Control Screening is the leading worldwide producer of fast, reliable and sophisticated X-ray, Metal and Trace Detection screening systems. Visit us at www.controlscreening.com. Ask about our mobile and cargo systems. Our advanced systems and options are often integrated, leased or rented.

The AUTOCLEAR® 5333 (featuring a 53 cm wide x 33 cm high or 20.9" wide x 13" high tunnel opening) is a compact, lightweight and ergonomic conveyORIZED X-ray system designed to inspect briefcases, purses, cameras, laptops, backpacks, shoes, mailbags, bins and parcels. Ideal for use at:

**Schools • Courthouses
Correctional Facilities
Corporate Facilities • Mailrooms
Embassies
Government Buildings
Special Events • Airports
Military Bases • Banks
Police Stations
Nightclubs • Law Firms
Executive Mail**

Features

- ➔ 90 kV, 10mm penetration is standard, double the penetration available elsewhere, eliminating hand searches and improving image quality.
- ➔ Ergonomic height and smaller footprint enhances security and fits in narrow doorways, elevators and spaces; conveyor folds for transport.
- ➔ Parcel contents are displayed at normal scale, wherever located, automatically and without distortion (autoScale®). RealClear® function reveals components of dense items in realtime without lags or delays.
- ➔ Features Pentium 4, 17" monitor, RealClear®, autoScale®, autoDensAlert®, autoOutline®, autoSensing®, autoCal®, 64X Smart Zoom, Lighten, Help, DensityScan, and Low Density Stripping, among other features.
- ➔ Multi-Energy Color option with Organic/Inorganic Stripping is popular. TIP, Training and Image Archiving also available. autoMatalert®, option highlights suspect materials using atomic number and density.
- ➔ autoTracking® guided conveyor belt system never needs adjustment, lowering operating costs.
- ➔ autoSensing® eliminates the need for troublesome photosensors or footpad switch. Assures 100% screening of thin blades or plastique in magazines or courier envelopes, or of bag already in tunnel at start-up.
- ➔ Interactive training and highly responsive local service. Engineered, made and rigorously tested in the USA to ISO 9001 and regulatory standards.



RealClear® reveals components of a gun, knife, narcotics in bottle, and bomb in real time, without lags and delays. autoScale® displays contents at Pentium 4 resolution automatically and without distortion.



User-friendly, ergonomic and fully-featured operator control panel.

Celebrating 65 years of excellence in design & support

AUTOCLEAR

ControlScreening.com

Scintrex® • Federal Labs® • CheckGate® • HandWand® • Dynavision® • RealClear®
U.S. Canada Europe Middle East Latin America Hong Kong Singapore

Model 5333 Compact X-ray Specifications

Overall Dimensions: Inspection Capabilities

Tunnel Size:	125.4 cm (49.4") L x 72.1 cm (28.4") W x 111.4 cm (43.6") H
Material Penetration:	20.9" wide (53 cm)
Contrast Sensitivity:	13" high (33 cm)
Resolution:	L-shaped detector for 100% package screening.
Processing:	10 mm (0.39") steel, twice the penetration in its class.
Conveyor Speed:	Over 2 million color tones standard.
Pulling Weight:	40 AWG wire.
autoTracking®:	24-bit color processing with minimum 128 Mbytes memory;
Film Safety:	800 MHz or 2.4 GHz processor.
	48 feet per minute; 24 cm per second.
	150 kg (331 lbs) standard; 403.2 kg (887 lbs) option
	Belt guaranteed to autoTrack for life.
	Guaranteed for high-speed films up to ISO 1600 (33 DIN).

***Full autoSensing® without photosensors, moving parts, or footpad.**

Reduces downtime and assures all magazines, envelopes or items are scanned, no matter how thin, or of bag already in tunnel at start-up. Enhances radiation safety.

X-ray Generator

X-ray tube head:	Self-contained
High voltage rating:	90 kV standard
Duty cycle:	100% with sealed oil bath cooling
Beam orientation:	Diagonal 80°
Dose rate per exam:	0.1 mR. Lower doses available.

X-ray Detectors

Surface mounted, multilayer, fully integrated, high frequency, solid state detectors using high speed processors, and Pentium 4 image processing with Single Energy or optional Multi-Energy (M) Color.

Video

Standard with color 17" SVGA monitor. High resolution, flicker-free, .28 dot pitch, low rad. monitor, 1280 x 1024. Single energy color is based on object density. Multi-Energy color option available with available second monitor or flat screen or larger monitor(s), displays organics in orange and inorganics in blue, both overlapping in green and very dense objects in black, and includes Organic and Inorganic Stripping.

Standard Features

- RealClear®
- autoDensAlert®
- autoTracking®
- autoSensing®
- autoOutline®
- autoScale®
- autoCal®
- 64X smart zoom
- Dark & Light enhance
- DensityScan
- Color; Reverse B/W
- High/Low Density & Stripping
- High density
- Brushed aluminum tunnel extensions
- Help
- Fast (25 second) initial warm-up
- Fully functional, robust, low profile
- Reversible conveyor direction

Options

- Multi-Energy (M) color material identification with organic and inorganic stripping
- Threat Image Projection (TIP)
- autoMatalert®
- Tropical Humidity Kit
- Loading or exit trays or rollerbeds
- Image Archiving
- LCD, dual or larger monitors
- Locking metal keypad cover
- Clear Lexan conveyor cover
- CE marking or UK approved
- kV, mA meter or item counter
- Power conditioner, or UPS
- Footpad or optical On/Off
- Variable height keypad mount
- Locking monitor hood
- Remote; printer or VCR cable
- Built-in Training
- Rental or leases
- Rollerbeds

Physical Details

Dimensions:	See drawing
Weight:	514 lbs (233 kg) (including undercarriage) 689 lbs (312 kg) crated
Construction:	Unibody heavy gauge epoxy painted steel construction with stainless steel and aluminum trim and accessories. Non-marring casters. Stainless steel command center keypad mountable on top, or optional on side or table.
Environmental Conditions:	Temperature range: 23° to 131° F, -5° to 55° C • Humidity 20% - 95%, non-condensing. Storage to 65° C (149° F)
Electrical Power Requirements:	Consumption: < 0.6 kVA 100, 120, 230 volts AC + 10%, < 6 amps. 200, 220, 240, 250 volts AC ± 10%, < 3 amps. All at 50 or 60 Hz.

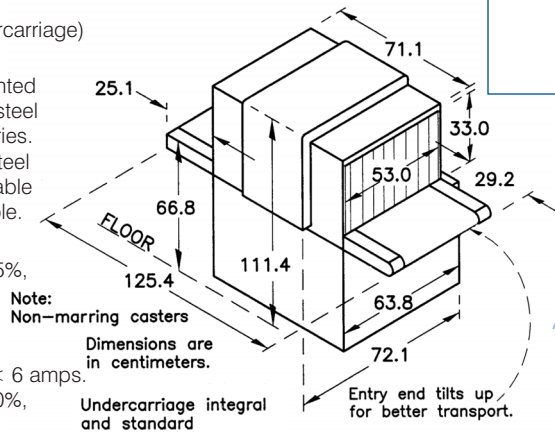

Distributor:

www.controlscreening.com

**World Headquarters
Domestic, Federal
& Corporate Sales**

2 Gardner Road
Fairfield, NJ 07004-2206 USA
Tel: + (973) 276-6161
Fax: + (973) 276-6162
leads@controlscreening.com

Western U.S.

Tel: + (760) 326-9114
Fax: + (760) 326-4734
sw@controlscreening.com

Continental Europe

Saint Jean de Braye, France
Tel: + 33 2 38 61 97 00
Fax: + 33 2 38 61 97 01
eu@controlscreening.com

Canada

Scintrex Trace Corp.

300 Parkdale Ave., Ottawa
Ontario, Canada K1Y 1G2
Tel: + (613) 224-1061
Fax: + (613) 224-2603
info@tracedetection.com

Asia

Singapore
Tel: + 65 9819-2473
Fax: + 65 6234-0813
asia@controlscreening.com

Latina/América Central

Santo Domingo,
Dominican Republic
Tel: + (809) 541-1844
Fax: + (809) 563-6672
latina@controlscreening.com

Middle East

Dubai, UAE
Tel: + 971 50 558 0689
Cell: + 971 50 683 9771
ME@controlscreening.com



www.controlscreening.com
www.tracedetection.com www.fed-labs.com



Celebrating 65 years of excellence in design & support
Scintrex® • Federal Labs® • CheckGate®
HandWand® • Dynavision® • RealClear®

Compliance Complies with the U.S. Federal Aviation Administration Standards "Use of X-Ray Systems" (Federal Standards 14 CFR 108.17 and 14 CFR 129.26); the system conforms to the USBRH Performance Standards for Cabinet X-Ray Systems (21 CFR 1020.40), ISO 9001 compliant. Emergency Stop buttons. Cluster LED X-Ray "ON" indicators for lower maintenance. The electrical system conforms to applicable sections of IEC 348 for Electrical Safety and FCC Docket 20780 for Electromagnetic capability.